

9

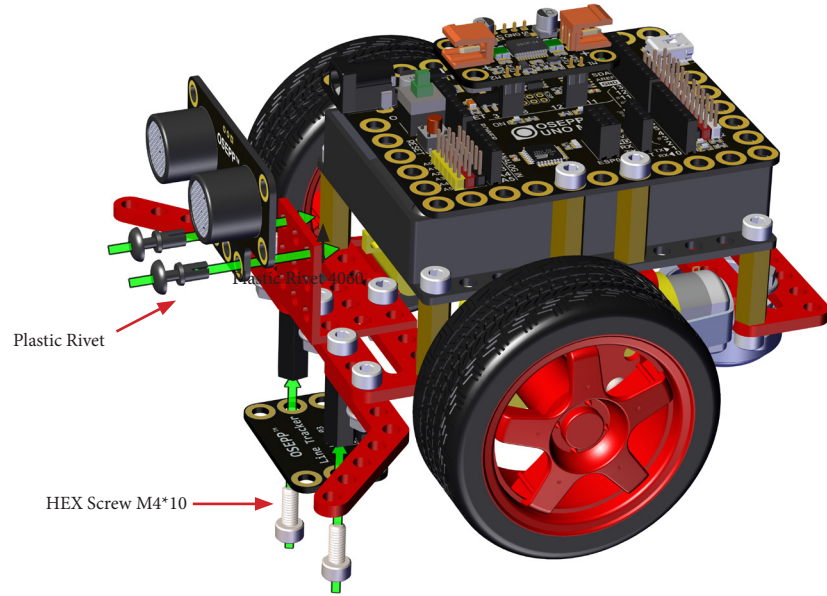

10

WIRING

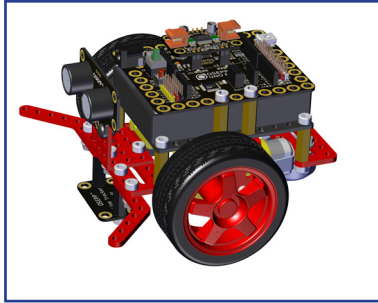
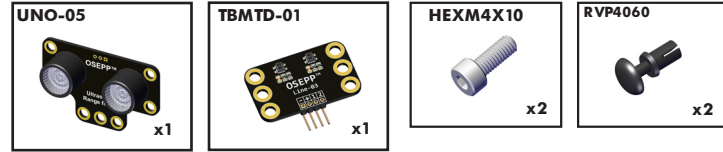
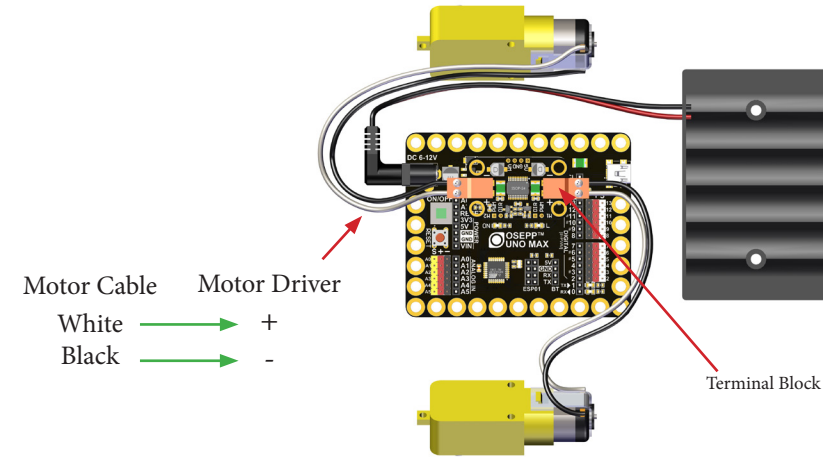

11

WIRING

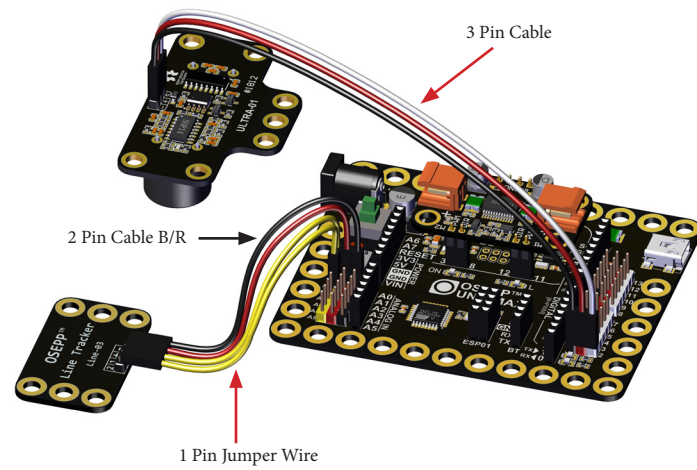
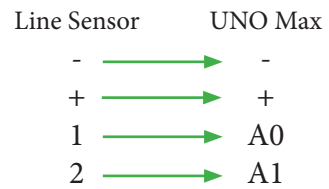
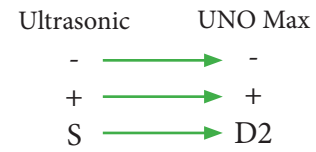
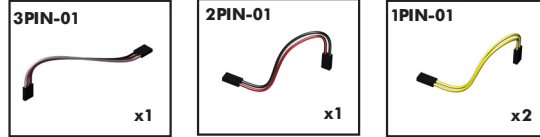

PARTS LIST

<b>UNO-05</b> UNO Max x1	<b>TBMTD-01</b> TB6612 Motor Driver x1	<b>ULTRA-01</b> Ultrasonic Sensor x1	<b>LINE-01</b> Line Sensor x1
<b>TTMT-01</b> TT Gear Motor x2	<b>BP11X9</b> Base Plate x1	<b>TTWL-01</b> TT Wheel x2	<b>BAT6AA</b> 6AA Battery Holder x1
<b>PLA-45°</b> Plate 45° x2	<b>BR3X3</b> Bracket 3*3 x1	<b>PLI3X9</b> Plate 3*9 x2	<b>TTBR-01</b> TT Motor Bracket x2
<b>STF-M4X20</b> Standoff M4x20mm x8	<b>RVP4060</b> Plastic Rivet 4060 x4	<b>PR4X7X8</b> Plastic Ring x2	<b>TBK-001</b> Terminal Block x2
<b>PSTF-M4X18</b> Plastic Standoff M4x18mm x2	<b>HEXM4X16</b> HEX Screw M4*16 x2	<b>HEXM4X10</b> HEX Screw M4*10 x18	<b>SCM3X25</b> Screw M3*25mm x4
<b>NUTM3</b> Nut M3 x4	<b>NUTM4</b> Nut M4 x6	<b>BCAST</b> Ball Caster Wheel x1	<b>3PIN-01</b> 3 Pin Cable x1
<b>3PIN-01</b> 3 Pin Cable x1	<b>2PIN-01</b> 2 Pin Cable B/R x1	<b>1PIN-01</b> 1 Pin Jumper Wire x2	

# ROBO PRO

## Assembly Instructions

[www.osepp.com](http://www.osepp.com)

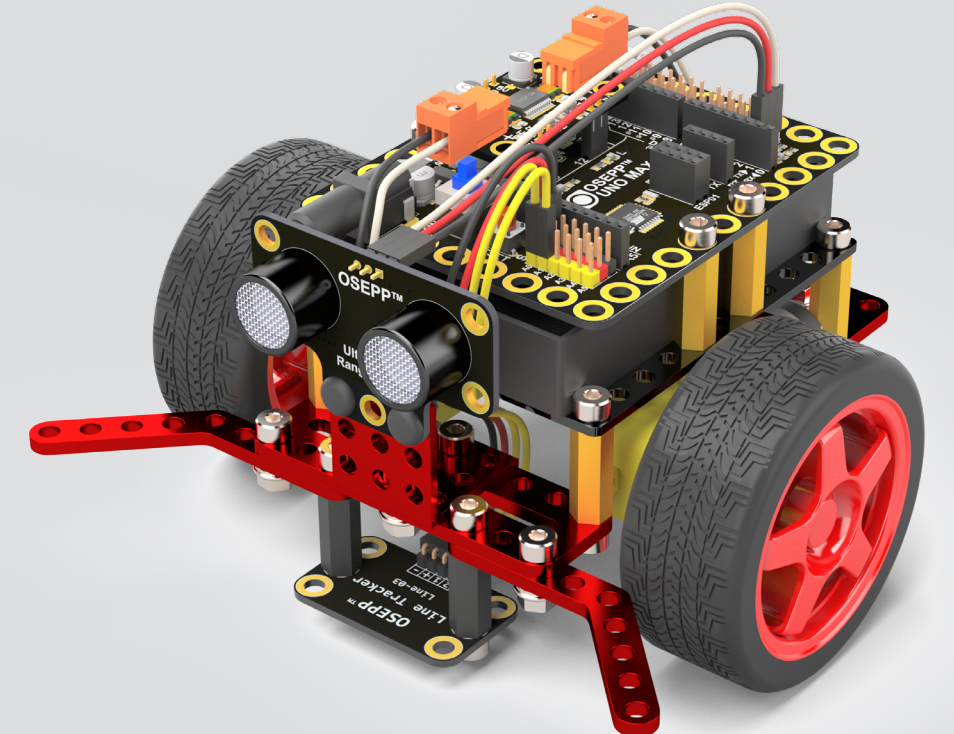

**ROBO-01**



**1**

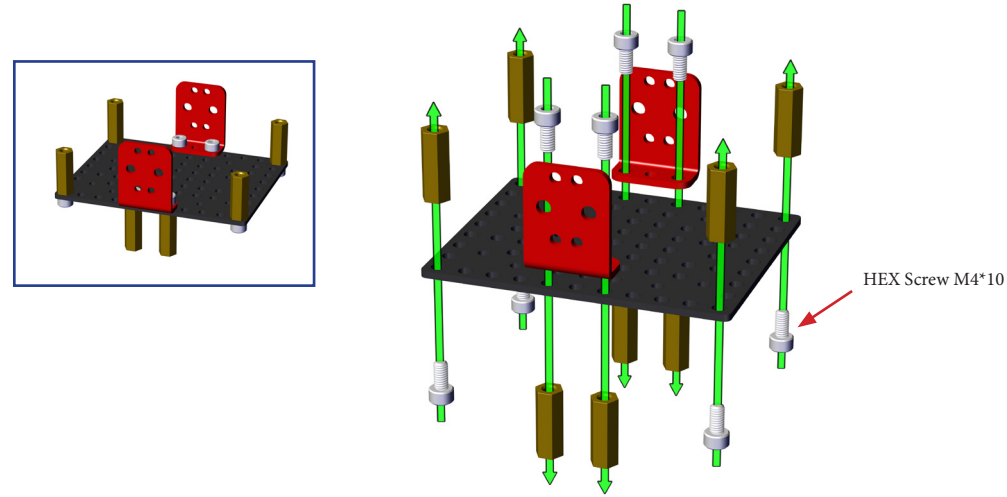
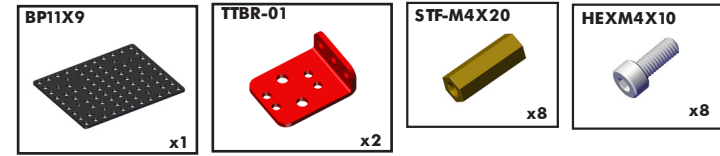

**3**

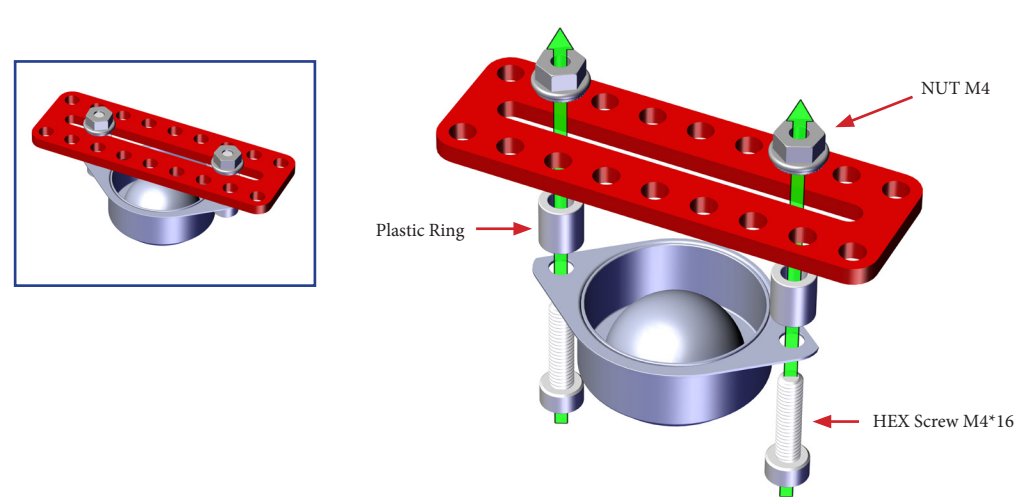
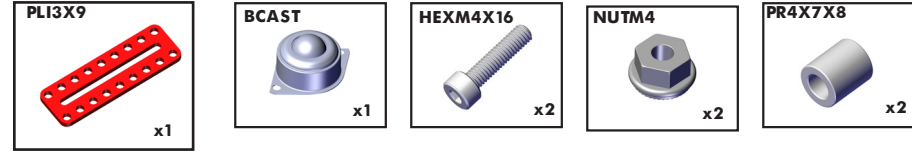

**5**

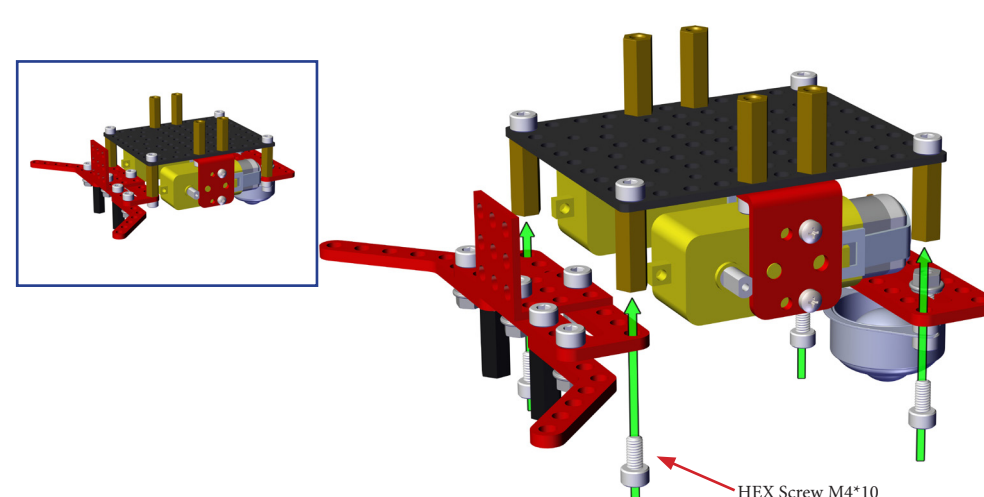

**7**

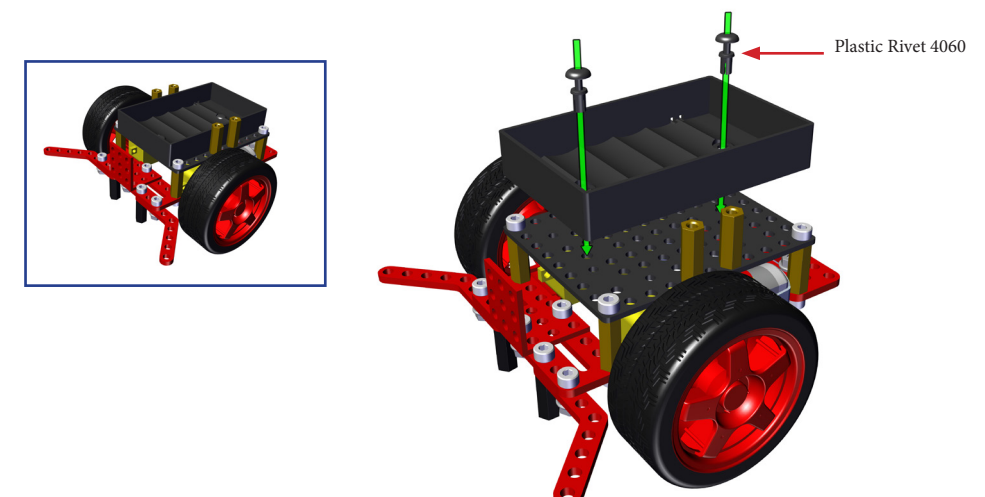
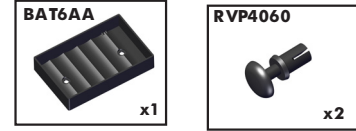

**2**

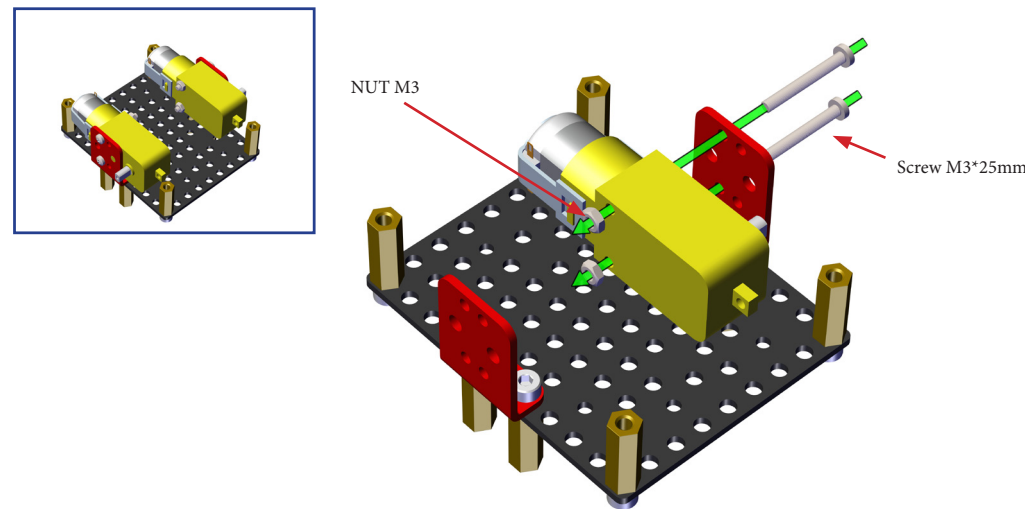
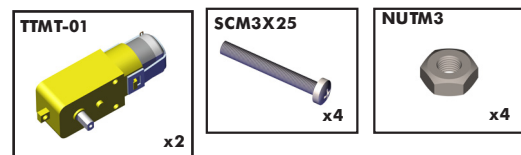

**4**

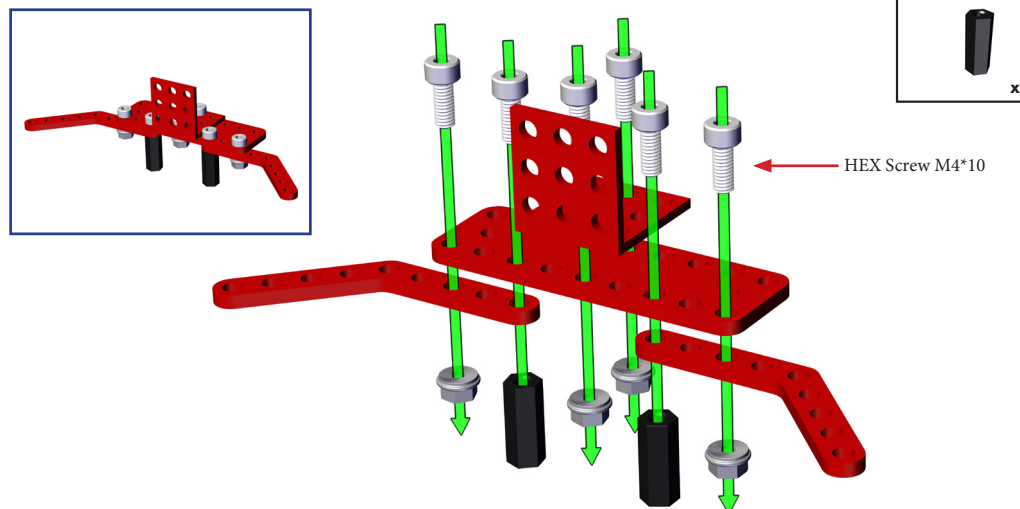
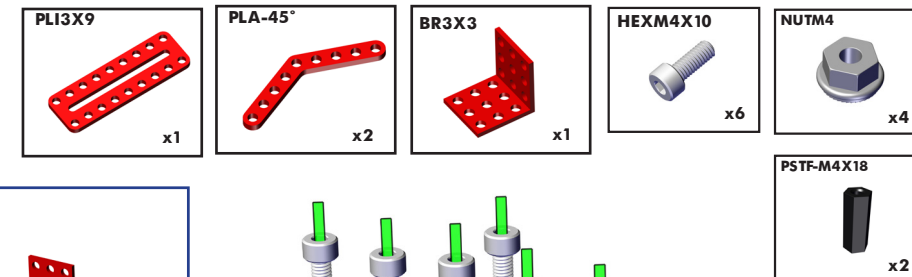

**6**

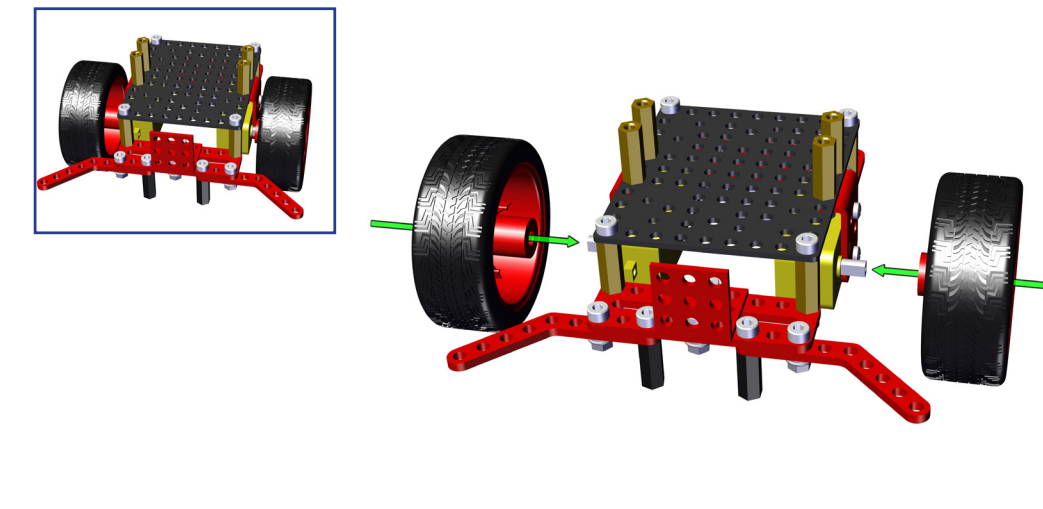

**8**

